

---

# MYRIAD

Long Chandelier

---



GABRIEL SCOTT  
EST 2012



[www.GabrielScott.com](http://www.GabrielScott.com)

# MYRIAD

## Long Chandelier

1/9

The Myriad series is the newest addition to the GABRIEL SCOTT lighting family. Inspired by nature's bioluminescent organisms, this modular series is made up of the brand's signature double-blown glass and satin metallic hardware. Its articulated stems carry the soft-lit pivoting heads to create a delicate, asymmetric and ever-changing silhouette.

These fine, jewel-like fixtures are offered in assorted arrangements and available in various metal and glass finishes.

All Gabriel Scott pieces are handmade in Canada.



—  
**triode**<sup>3</sup> design

—  
28, rue Jacob 75006 Paris  
+33 (0)1 43 29 40 05

—  
contact@triodedesign.com  
www.triodedesign.com

GABRIEL SCOTT

EST 2012



# MYRIAD

## Long Chandelier

2/9

triode<sup>3</sup> design

28, rue Jacob 75006 Paris  
+33 (0)1 43 29 40 05

contact@triodedesign.com  
www.triodedesign.com



GABRIEL SCOTT  
EST. 2012  

372 Broome Street, New York, NY 10013  
(212) 837-2923 • info@GabrielScott.com

www.GabrielScott.com

MYRIAD  
Long Chandelier

---

3/9

triode<sup>3</sup> design

---

28, rue Jacob 75006 Paris  
+33 (0)1 43 29 40 05

---

contact@triodedesign.com  
www.triodedesign.com



---

GABRIEL SCOTT

EST. 2012



372 Broome Street, New York, NY 10013  
(212) 837-2923 • info@GabrielScott.com

www.GabrielScott.com



# MYRIAD

## Long Chandelier

4/9

triode<sup>3</sup> design

28, rue Jacob 75006 Paris  
+33 (0)1 43 29 40 05

contact@triodedesign.com  
www.triodedesign.com



GABRIEL SCOTT  
EST. 2012  

372 Broome Street, New York, NY 10013  
(212) 837-2923 • info@GabrielScott.com

www.GabrielScott.com

## Spec sheet

Product name:	Myriad Chandelier
Standard Leadtime:	12-14 weeks
Dimensions:	x-Long (9x) 80" x 20" x 31" H + stem x-Long (13x) 80" x 20" x 38" H + stem Long (12x) 64" x 22" x 36.3" H + stem Short (7x) 30" x 18" x 26.5" H + stem
Standard Stem Lengths:	6", 12", 18" or 24"
Additional Stem Lengths: (up-charge applies)	30", 36", 42" or 48"
Light Source:	12V 6 Watt LED bulb (included)
LED driver:	E60R12DC (110V)  UVC50TD (220V) 
Weight:	60 lbs (short 7) 70 lbs (x-Long 9) 90 lbs (x-Long 12) 100 lbs (x-Long 13)

See installation guide for installation details

## Standard Finishes

Standard finish options:

BLOWN  
GLASS:



Ablaster White

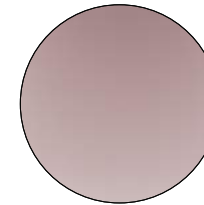

Soft Pink

FRAME:



Blackened Steel

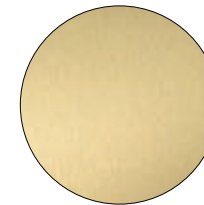

Satin Brass

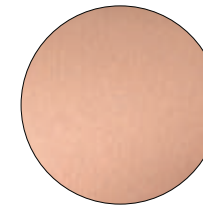

Satin Copper

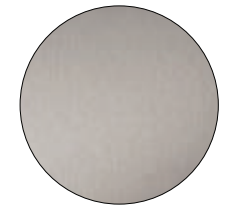

Satin Nickel

Standard 5" canopy & monopoint finish options:



Blackened Steel



Satin Brass

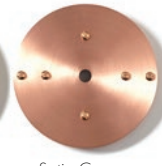

Satin Copper



Satin Nickel

# MYRIAD

## Long Chandelier

6/9

triode<sup>3</sup> design

28, rue Jacob 75006 Paris  
+33 (0)1 43 29 40 05

contact@triodedesign.com  
www.triodedesign.com

### Standard Dimensions

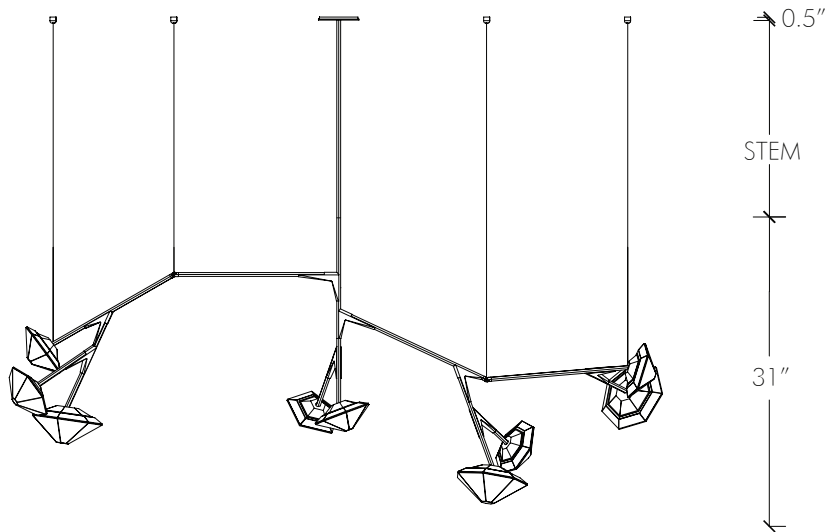
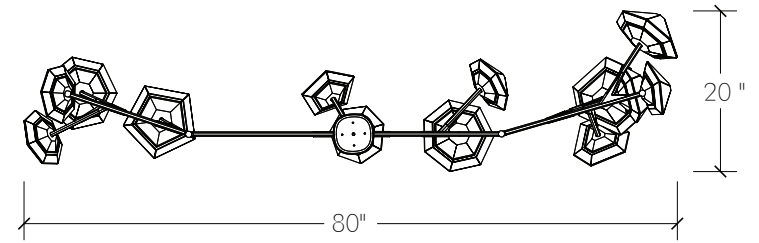
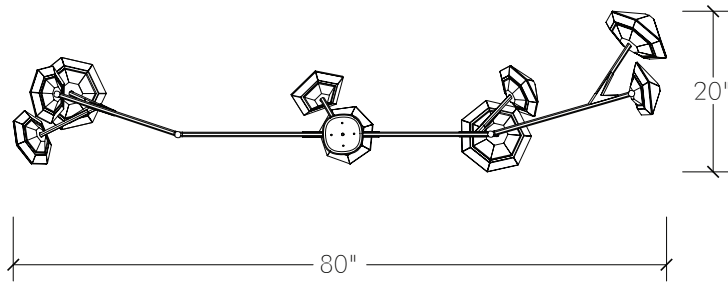

Myriad XLong -9

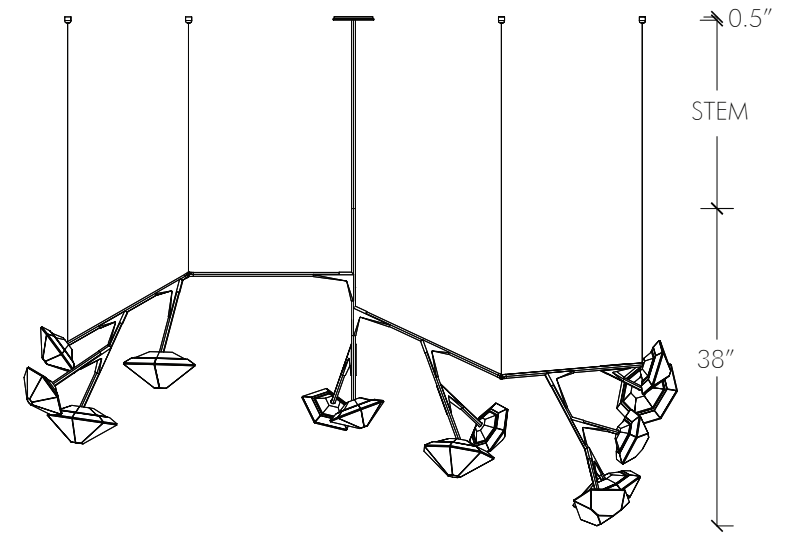

Myriad XLong -13

GABRIEL SCOTT



372 Broome Street, New York, NY 10013  
(212) 837-2923 • info@GabrielScott.com

www.GabrielScott.com

Standard Dimensions

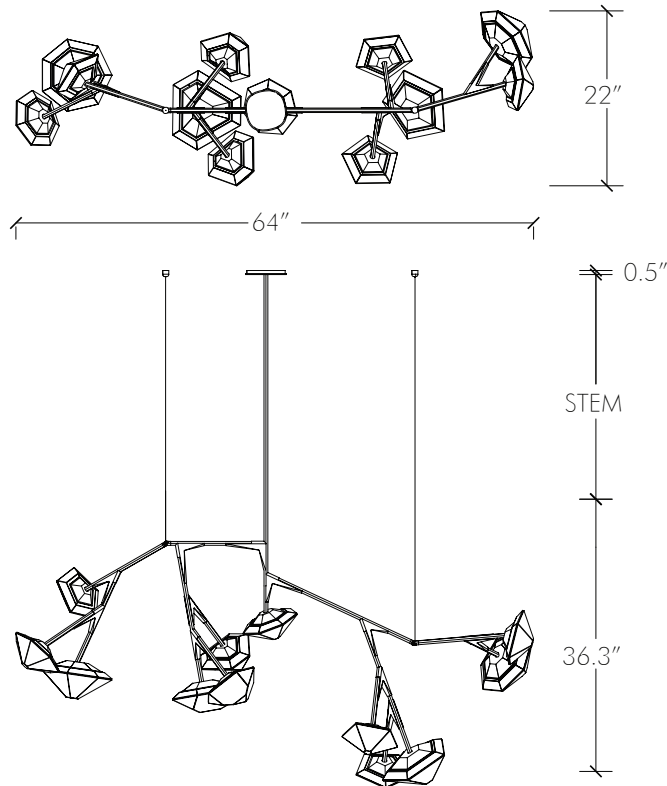

Myriad Long - 12

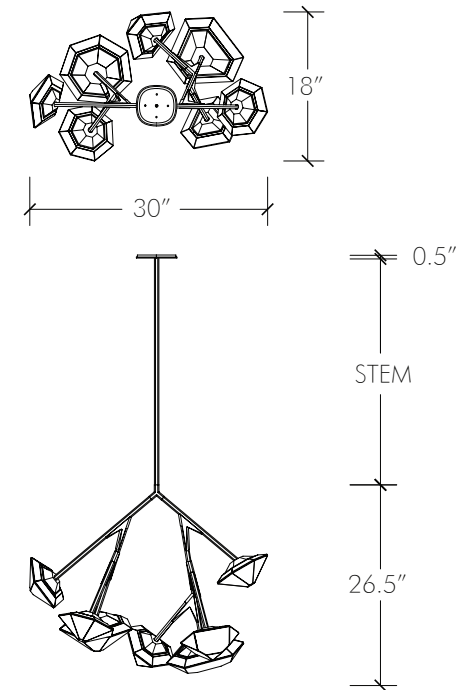

Myriad Short - 7





## 60W 12V DC LED Driver

### Features:

**Dimmable with any standard MLV/Incandescent TRIAC - (Leading edge) dimmer switch**  
**Super compact ALUMINUM CASE**  
**Class 2UL 8750IP67 - Withstands wet and salty conditions**  
**Auto-Reset Protection for short circuits & over-voltage**  
**FCC 15 part 212V DC**  
**True RMS**

### Specifications:

Max Load	60W
Input Voltage	120V AC
Input Current at Max Load	0.61 A
Output Voltage	12V DC
Output Current at Max load	5A
Power Factor	0.95
Efficiency	> 90 %
Operating Temp.	-20c ~ 70c (-4F ~ 158F)
Overcurrent	Yes
Over temperature	Yes
Open circuit protection	Yes
Input Wires (White / Black)	18 AWG
Output Wires (Red / Black)	14 AWG
Dimensions	4.92" x 1.97" x 0.77"
Weight	9 oz

Magnitude's E60R12DC dimmable voltage LED driver is class 2 rated and designed to operate with any standard MLV/Incandescent TRIAC (Leading edge) dimmer switch. The driver's low profile aluminum case makes it the perfect choice for under cabinet lights, tape lights and various LED fixtures installations. Our electrical specification includes Auto Reset, over current and short circuit protection. Efficiency of 90% and higher allows the driver to operate at low temperatures.

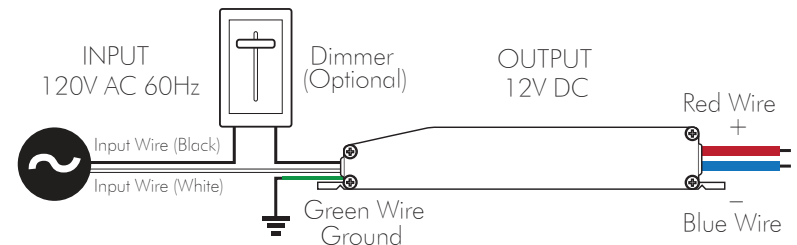
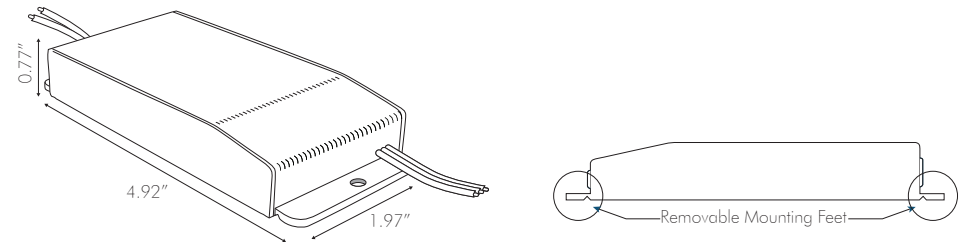

\*For smooth dimming 8W minimum load is required

## 50W Constant Voltage Triac Dimming LED Driver

### Specifications:

Input voltage	220V - 240VAC
Input frequency	50 - 60 Hz
Input current	0.4A
Inrush current	<2.5A
Power factor	0.95
Output load Voltage	12V
Output current	4.16A
Output power	50W
Power factor	>0.95
Efficiency TYP	>80%

### Protection:

Overload	Auto recovery
Short circuit	Auto recovery
Over Voltage	Auto recovery

### Environment:

Operating temp	-20c - +50c
Storage temp	-40c - +70c
Relative humidity	5 - 95 %

### Safety Standard:

Design refers to EN60598, EN61547, EN55024, EN61000-4-2, 3, 4, 6, 8,11, EN61000-3-2, EN61000-3-3

### EMI Standard:

Meets Emissions to EN55022, EN55015 Class B

### Weight:

200g

### Features:

Constant voltage output  
Fully isolated  
Short circuit, over current and over voltage protection up to 80% efficient  
Fire resistant plastic cover  
Compatible with leading and trailing edge dimmers  
20 ~ 100% Dimming Load  
10 ~ 100% Dimming range  
Mains dimmable  
Screw terminals  
IP44 design for indoor use  
2 years warranty

### Mechanical Diagram

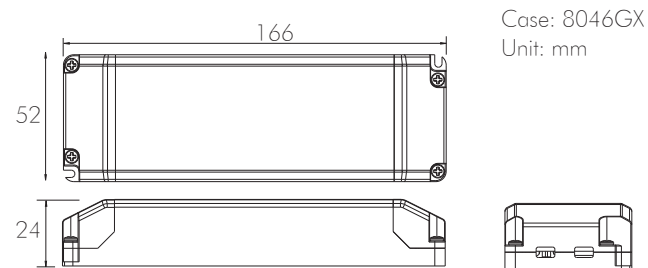

### LED Configuration

